

## Apparel Folding Equipments & Automation

# BagXcite



**BagXcite** PP-56 is a full automatic L-Sealer. The conveyor will feed directly into the **BagXcite** ; and the sealing process is triggered by a photo sensor.

### OVERVIEW

**BagXcite** PP-56 has a sealing system, capable of performing a smooth and firm seal line.

- Use of photo sensors and timers controls the bag length for sealing.
- Excellent perforation system design allows the pin to be changed easily.

# DEKKEN USA



Pin Wheel Hole Punch

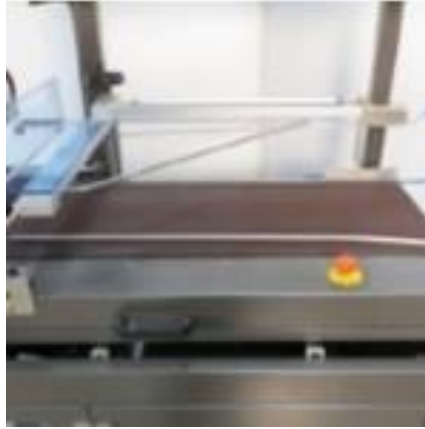

Adjustable Inverting Head with air injector for better looking Packages

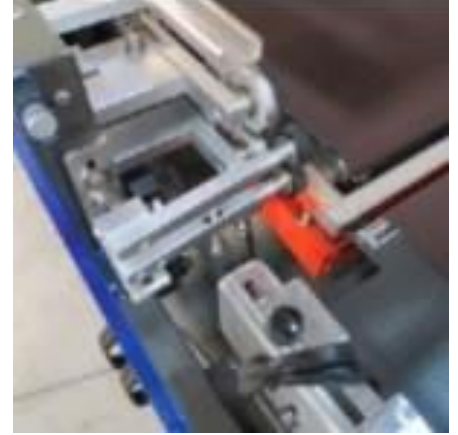

Film Miser – helps track film allowing for smaller width film rolls to save money

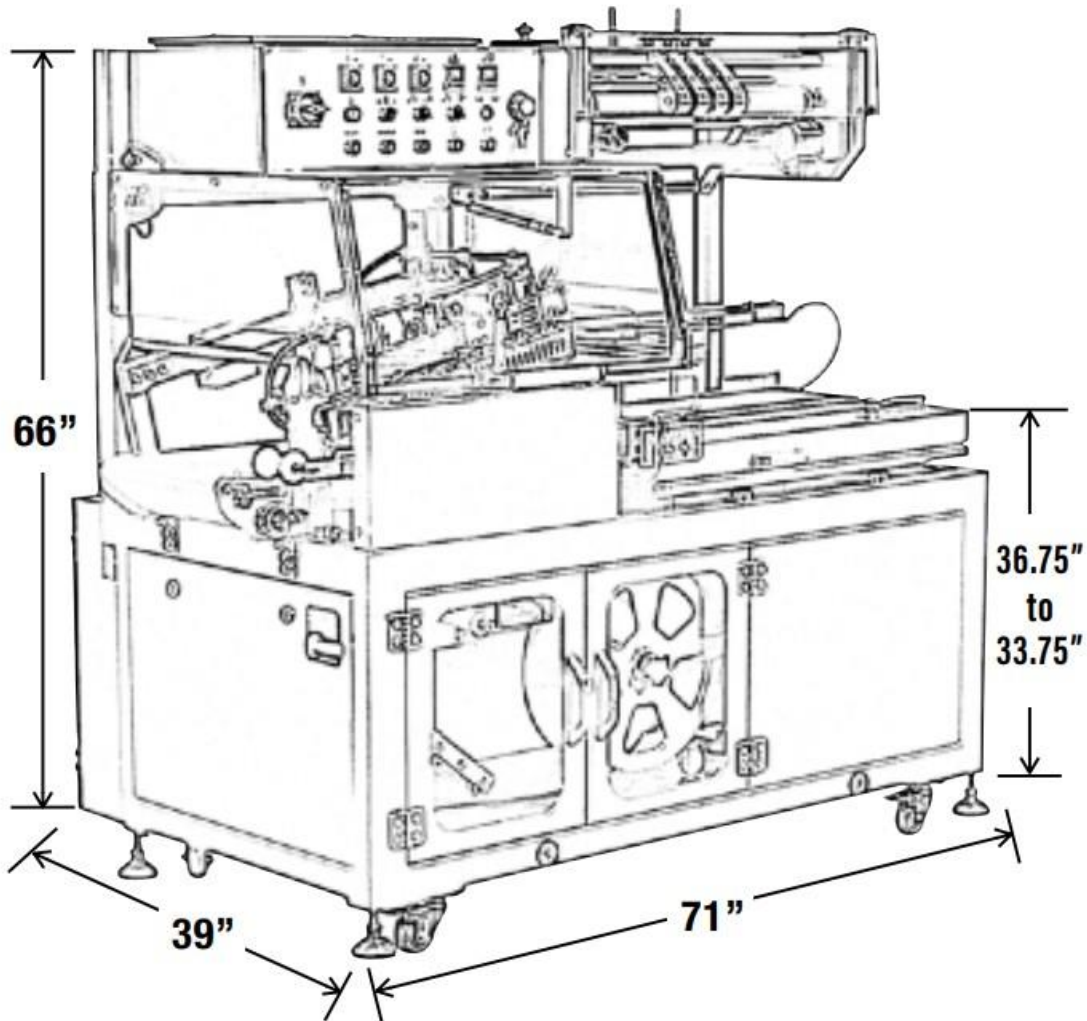

## KEY FEATURES

- Teflon coated hot knife seal blade
- Fixed belt speed at 65 FPM
- Multiple pinwheel hole punches
- Large seal area (22"L x 18"W x 4.75"H)
- Dual emergency stop switches
- Self-contained scrap removal system
- Plexi-glas safety covers
- Dual photo-eye (horizontal & vertical)
- Film miser – helps track film
- Locking casters with leveling pads
- Max film width os 24"

## SPECIFICATIONS

Seal Area: 22"L x 18"W x 4.75"H

Machine Speed: 20-25 PPM

Electrical 220V: 1 Phase, 20 Amp

Air: 2 cfm @ 80 psi

Minimum pkg size: 3.9" x 2.5" x 1/8"

Maximum pkg size: 21"L x 17"W x 4.75"

Maximum film width: 24"

Machine dimensions: Crated dimensions 75"L x 43"W x 74"H

Shipping weight: 880 lbs

Warranty: 1 year on parts

## OPTIONS

- 3ft or 6ft flighted infeed
- 3ft or 6ft belted conveyors
- Flight bar conveyors for multi-packs
- Variable speed conveyor (0-90 FPM)
- Closing conveyor
- Print registration



## **Contact:**

**DEKKEN USA, INC**

**805 Essex Drive**

**Summerville, SC 29485**

**Ph.: 843.708.8444**

**e-mail: [info@dekkenusa.com](mailto:info@dekkenusa.com)**

**Web: <https://dekkenusa.com/>**